



PHILIPS SERVICE

BD 653 A-S

10 Röhren AM/FM Super mit Hi-Fi Endstufe

Saturn-Tonmeister 653

Hochtonstrahler und Baßreflexbox

Technische Daten:

Wellenbereiche: FM: UKW 87,5 — 100 MHz
 AM: KW 5,85 — 12,2 MHz
 MW 518 — 1622 kHz
 LW 148 — 350 kHz

Schaltung: FM: 11 Kreise (HF + HF var + HF var + 4 x 2ZF) 2 Sperrkreise.

AM: 8 Kreise (HF var + HF var + 3 x 2ZF) 2 Saugkreise

Tondemodulation: FM: Ratiodektor
 AM: Diode

Zwischenfrequenz: FM: 10,7 MHz
 AM: 460 kHz

Netzspannungen: 110, 125, 145, 220 Volt

Sicherung: 0,5 Amp. träge (08 141 14)

Skalenslampen: 7996 D (7 Volt, 0,3 Amp.)

Leistungsaufn.: ca. 90 Watt

Lautsprecher: WA 188 LZ (-01)
 WA 187 LZ od. WA 193 LZ
 Z = 800 Ω

Abmessungen: Breite 680 mm
 Höhe 290 mm
 Tiefe 270 mm

Fertigungsaison: 1955/56

Bedienungsknöpfe:

rechts: Abstimmung

links: Lautstärkeregler

Rändelrädchen links oben: Höhenregler

Rändelrädchen links unten: Baß-Regler

Rändelrädchen rechts: Ferroceptor

Drucktasten von links nach rechts

a) Aus

b) TA

c) LW

d) MW

e) KW

f) UKW

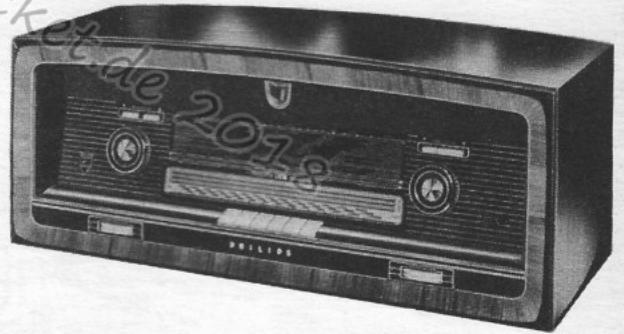

Spulenanschlüsse

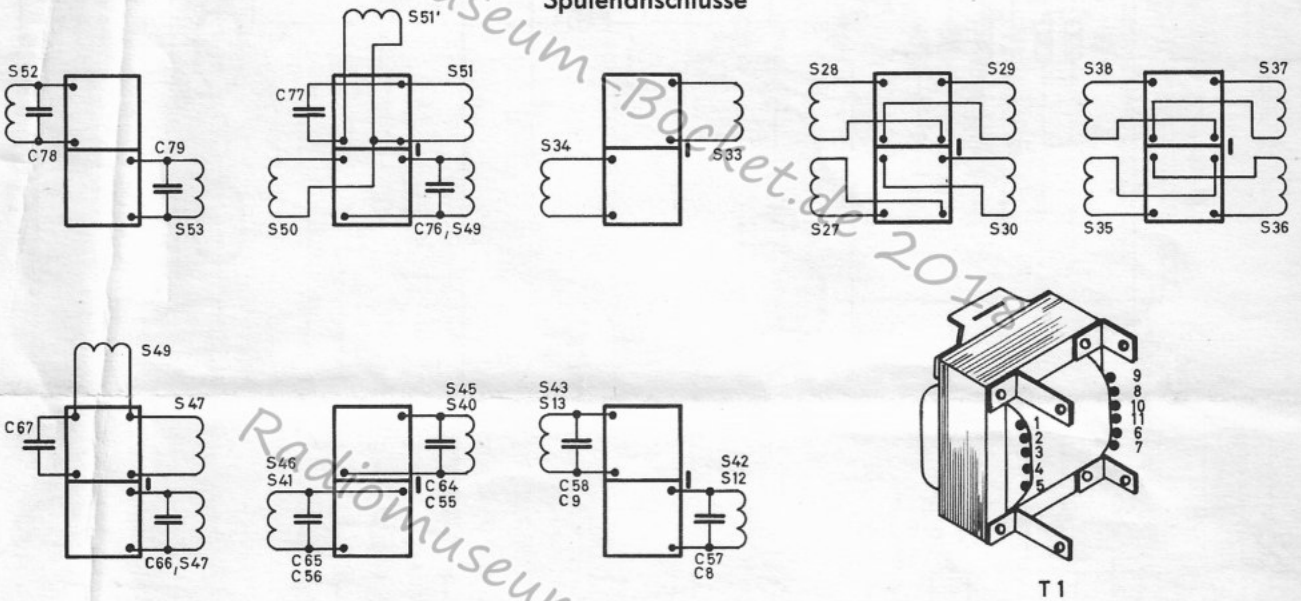

Seilführungsplan

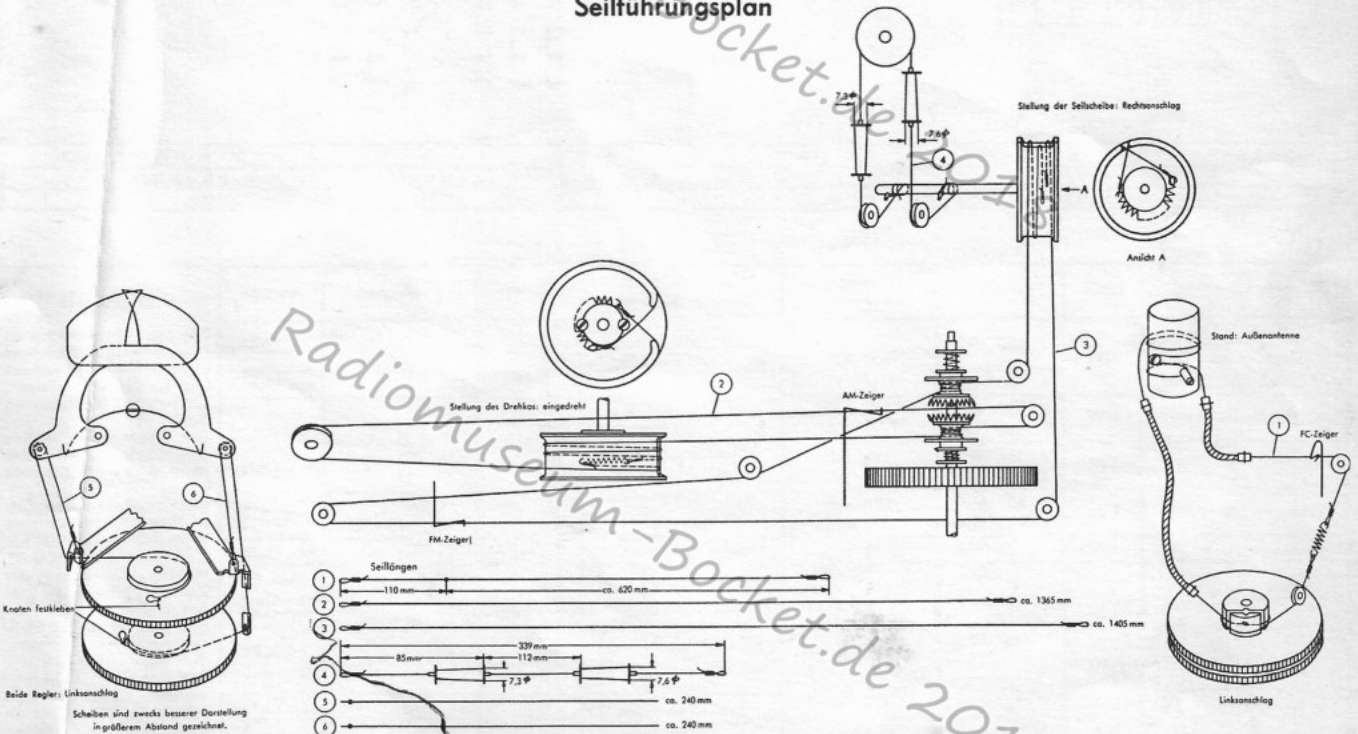



PHILIPS SERVICE

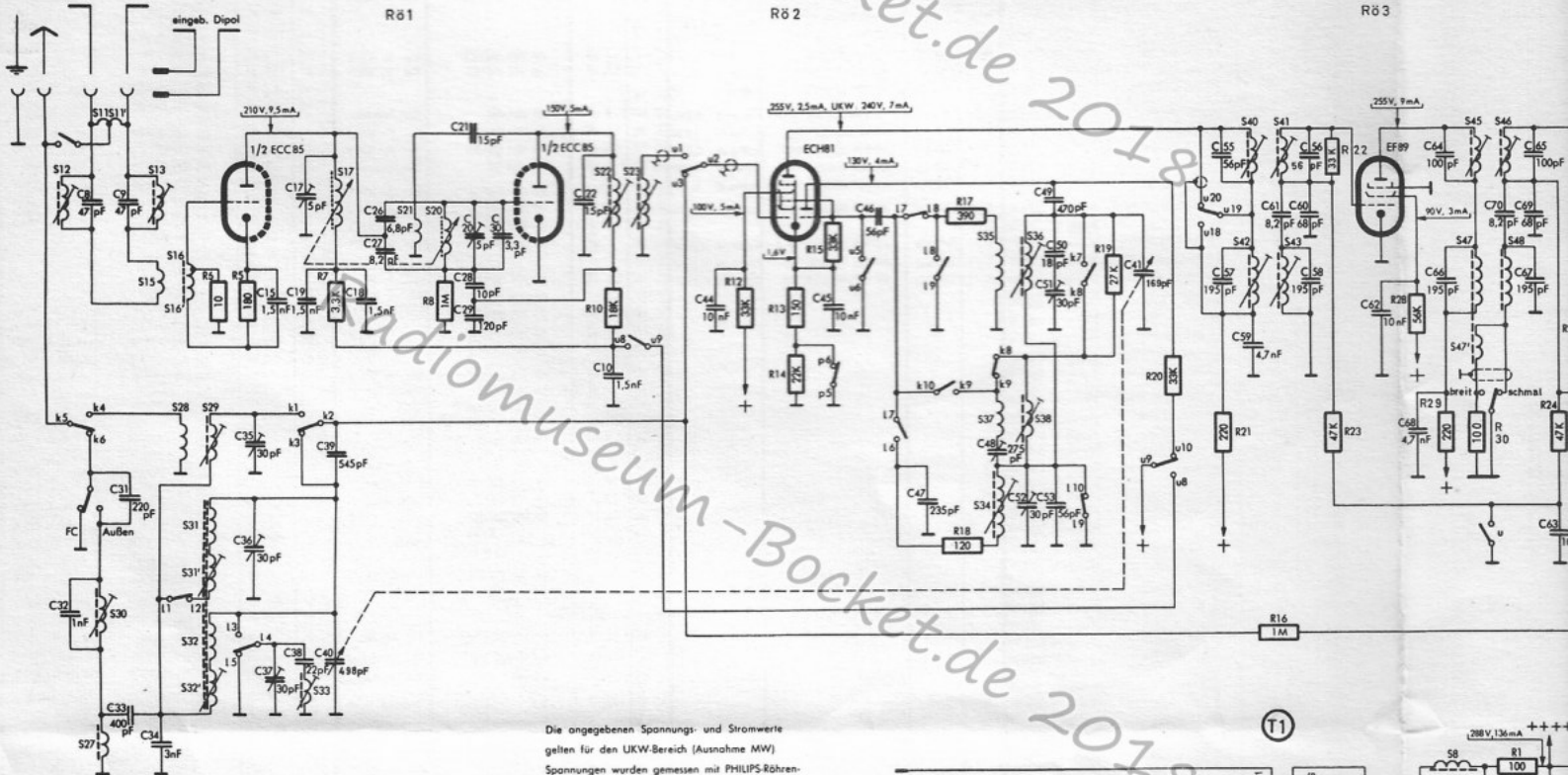

Die angegebenen Spannungs- und Stromwerte gelten für den UKW-Bereich (Ausnahme MW). Spannungen wurden gemessen mit PHILIPS-Röhrenvoltmeter GM 6004.

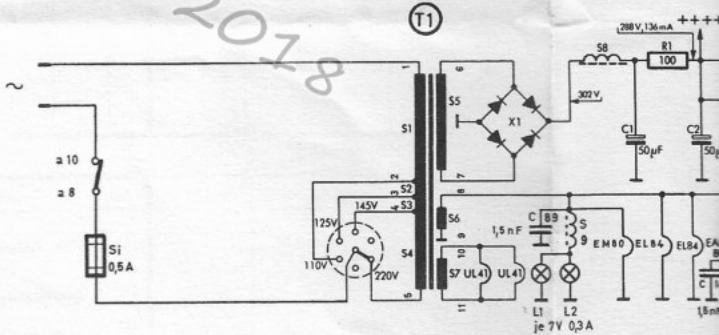
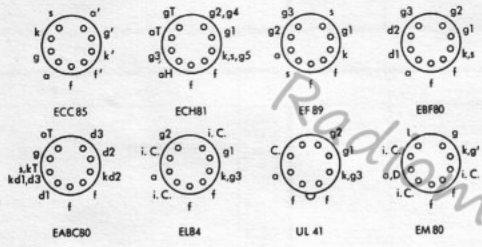

S	12, 11, 11', 30, 27, 13, 15, 16, 16', 28, 29, 31, 31', 32, 32', 33, 17, 21, 20, 22, 23, 35, 37, 34, 36, 38, 1, 2, 3, 4, 40, 42, 41, 43, 5, 6, 7, 9, 8, 45, 47, 47', 46, 48,
CR	32, 8, 9, 31, 33, 34, 6, 5, 7, 8, 10, 12, 13, 14, 15, 17, 18, 19, 20, 21, 16, 22, 23, 28, 29, 30, 1, 24, 25, 26, 27, 28, 29, 30, 22, 10, 44, 45, 46, 47, 48, 49, 50, 51, 53, 41, 55, 57, 59, 61, 56, 60, 58, 62, 63, 64, 64', 66, 1, 70, 65, 69, 67, 68, 69, 70, 71, 72, 73, 74, 75, 76, 77, 78, 79, 80, 81, 82, 83, 84, 85, 86, 87, 88, 89, 90, 91, 92, 93, 94, 95, 96, 97, 98, 99, 100, 101, 102, 103, 104, 105, 106, 107, 108, 109, 110, 111, 112, 113, 114, 115, 116, 117, 118, 119, 120, 121, 122, 123, 124, 125, 126, 127, 128, 129, 130, 131, 132, 133, 134, 135, 136, 137, 138, 139, 140, 141, 142, 143, 144, 145, 146, 147, 148, 149, 150, 151, 152, 153, 154, 155, 156, 157, 158, 159, 160, 161, 162, 163, 164, 165, 166, 167, 168, 169, 170, 171, 172, 173, 174, 175, 176, 177, 178, 179, 180, 181, 182, 183, 184, 185, 186, 187, 188, 189, 190, 191, 192, 193, 194, 195, 196, 197, 198, 199, 200, 201, 202, 203, 204, 205, 206, 207, 208, 209, 210, 211, 212, 213, 214, 215, 216, 217, 218, 219, 220, 221, 222, 223, 224, 225, 226, 227, 228, 229, 230, 231, 232, 233, 234, 235, 236, 237, 238, 239, 240, 241, 242, 243, 244, 245, 246, 247, 248, 249, 250, 251, 252, 253, 254, 255, 256, 257, 258, 259, 260, 261, 262, 263, 264, 265, 266, 267, 268, 269, 270, 271, 272, 273, 274, 275, 276, 277, 278, 279, 280, 281, 282, 283, 284, 285, 286, 287, 288, 289, 290, 291, 292, 293, 294, 295, 296, 297, 298, 299, 300, 301, 302, 303, 304, 305, 306, 307, 308, 309, 310, 311, 312, 313, 314, 315, 316, 317, 318, 319, 320, 321, 322, 323, 324, 325, 326, 327, 328, 329, 330, 331, 332, 333, 334, 335, 336, 337, 338, 339, 340, 341, 342, 343, 344, 345, 346, 347, 348, 349, 350, 351, 352, 353, 354, 355, 356, 357, 358, 359, 360, 361, 362, 363, 364, 365, 366, 367, 368, 369, 370, 371, 372, 373, 374, 375, 376, 377, 378, 379, 380, 381, 382, 383, 384, 385, 386, 387, 388, 389, 390, 391, 392, 393, 394, 395, 396, 397, 398, 399, 400, 401, 402, 403, 404, 405, 406, 407, 408, 409, 410, 411, 412, 413, 414, 415, 416, 417, 418, 419, 420, 421, 422, 423, 424, 425, 426, 427, 428, 429, 430, 431, 432, 433, 434, 435, 436, 437, 438, 439, 440, 441, 442, 443, 444, 445, 446, 447, 448, 449, 450, 451, 452, 453, 454, 455, 456, 457, 458, 459, 460, 461, 462, 463, 464, 465, 466, 467, 468, 469, 470, 471, 472, 473, 474, 475, 476, 477, 478, 479, 480, 481, 482, 483, 484, 485, 486, 487, 488, 489, 490, 491, 492, 493, 494, 495, 496, 497, 498, 499, 500, 501, 502, 503, 504, 505, 506, 507, 508, 509, 510, 511, 512, 513, 514, 515, 516, 517, 518, 519, 520, 521, 522, 523, 524, 525, 526, 527, 528, 529, 530, 531, 532, 533, 534, 535, 536, 537, 538, 539, 540, 541, 542, 543, 544, 545, 546, 547, 548, 549, 550, 551, 552, 553, 554, 555, 556, 557, 558, 559, 560, 561, 562, 563, 564, 565, 566, 567, 568, 569, 570, 571, 572, 573, 574, 575, 576, 577, 578, 579, 580, 581, 582, 583, 584, 585, 586, 587, 588, 589, 590, 591, 592, 593, 594, 595, 596, 597, 598, 599, 600, 601, 602, 603, 604, 605, 606, 607, 608, 609, 610, 611, 612, 613, 614, 615, 616, 617, 618, 619, 620, 621, 622, 623, 624, 625, 626, 627, 628, 629, 630, 631, 632, 633, 634, 635, 636, 637, 638, 639, 640, 641, 642, 643, 644, 645, 646, 647, 648, 649, 650, 651, 652, 653, 654, 655, 656, 657, 658, 659, 660, 661, 662, 663, 664, 665, 666, 667, 668, 669, 670, 671, 672, 673, 674, 675, 676, 677, 678, 679, 680, 681, 682, 683, 684, 685, 686, 687, 688, 689, 690, 691, 692, 693, 694, 695, 696, 697, 698, 699, 700, 701, 702, 703, 704, 705, 706, 707, 708, 709, 710, 711, 712, 713, 714, 715, 716, 717, 718, 719, 720, 721, 722, 723, 724, 725, 726, 727, 728, 729, 730, 731, 732, 733, 734, 735, 736, 737, 738, 739, 740, 741, 742, 743, 744, 745, 746, 747, 748, 749, 750, 751, 752, 753, 754, 755, 756, 757, 758, 759, 760, 761, 762, 763, 764, 765, 766, 767, 768, 769, 770, 771, 772, 773, 774, 775, 776, 777, 778, 779, 780, 781, 782, 783, 784, 785, 786, 787, 788, 789, 790, 791, 792, 793, 794, 795, 796, 797, 798, 799, 800, 801, 802, 803, 804, 805, 806, 807, 808, 809, 810, 811, 812, 813, 814, 815, 816, 817, 818, 819, 820, 821, 822, 823, 824, 825, 826, 827, 828, 829, 830, 831, 832, 833, 834, 835, 836, 837, 838, 839, 840, 841, 842, 843, 844, 845, 846, 847, 848, 849, 850, 851, 852, 853, 854, 855, 856, 857, 858, 859, 860, 861, 862, 863, 864, 865, 866, 867, 868, 869, 870, 871, 872, 873, 874, 875, 876, 877, 878, 879, 880, 881, 882, 883, 884, 885, 886, 887, 888, 889, 890, 891, 892, 893, 894, 895, 896, 897, 898, 899, 900, 901, 902, 903, 904, 905, 906, 907, 908, 909, 910, 911, 912, 913, 914, 915, 916, 917, 918, 919, 920, 921, 922, 923, 924, 925, 926, 927, 928, 929, 930, 931, 932, 933, 934, 935, 936, 937, 938, 939, 940, 941, 942, 943, 944, 945, 946, 947, 948, 949, 950, 951, 952, 953, 954, 955, 956, 957, 958, 959, 960, 961, 962, 963, 964, 965, 966, 967, 968, 969, 970, 971, 972, 973, 974, 975, 976, 977, 978, 979, 980, 981, 982, 983, 984, 985, 986, 987, 988, 989, 990, 991, 992, 993, 994, 995, 996, 997, 998, 999, 1000.

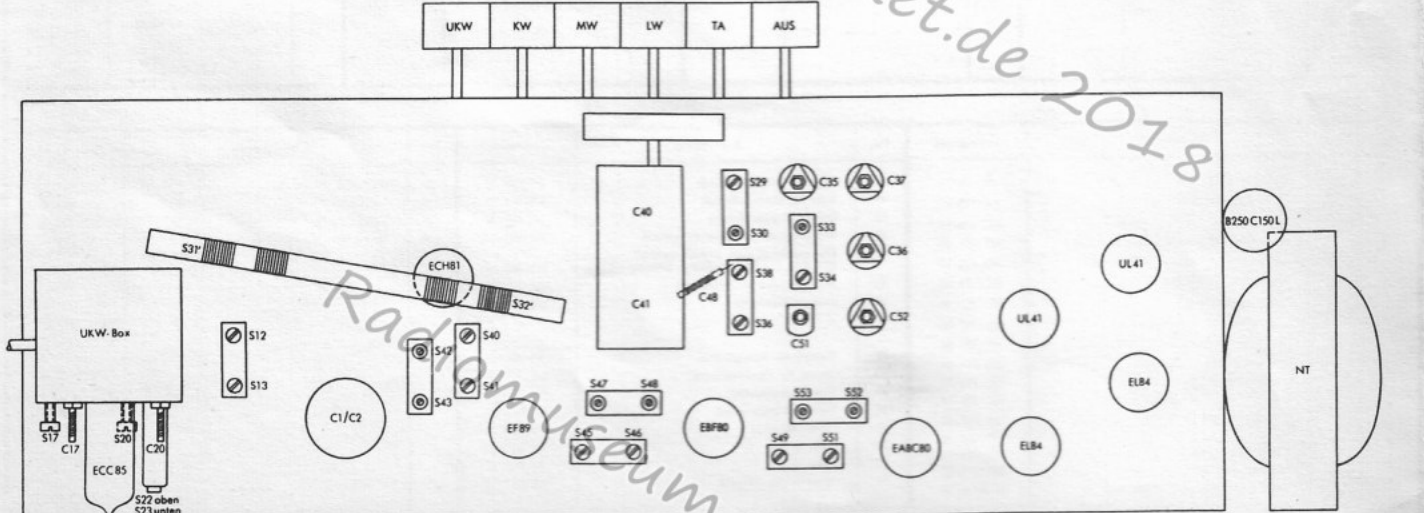

- Abgleich-Reihe
- ZF-Kreise
- ZF-Sperrkreise
- Abstimmkreise
- Abstimmkreise
- Abstimmkreise
- Spiegelsperre
- ZF-Kreise
- ZF-Sperrkreise
- Abstimmkreise

BD 653A-S

Saturn-Tonmeister 653

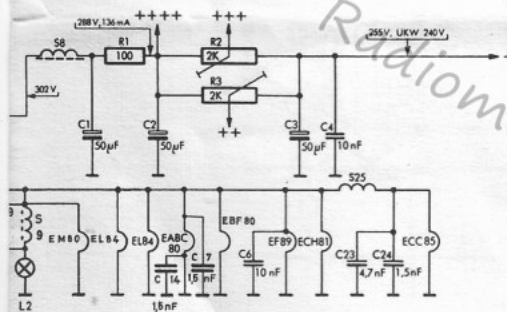
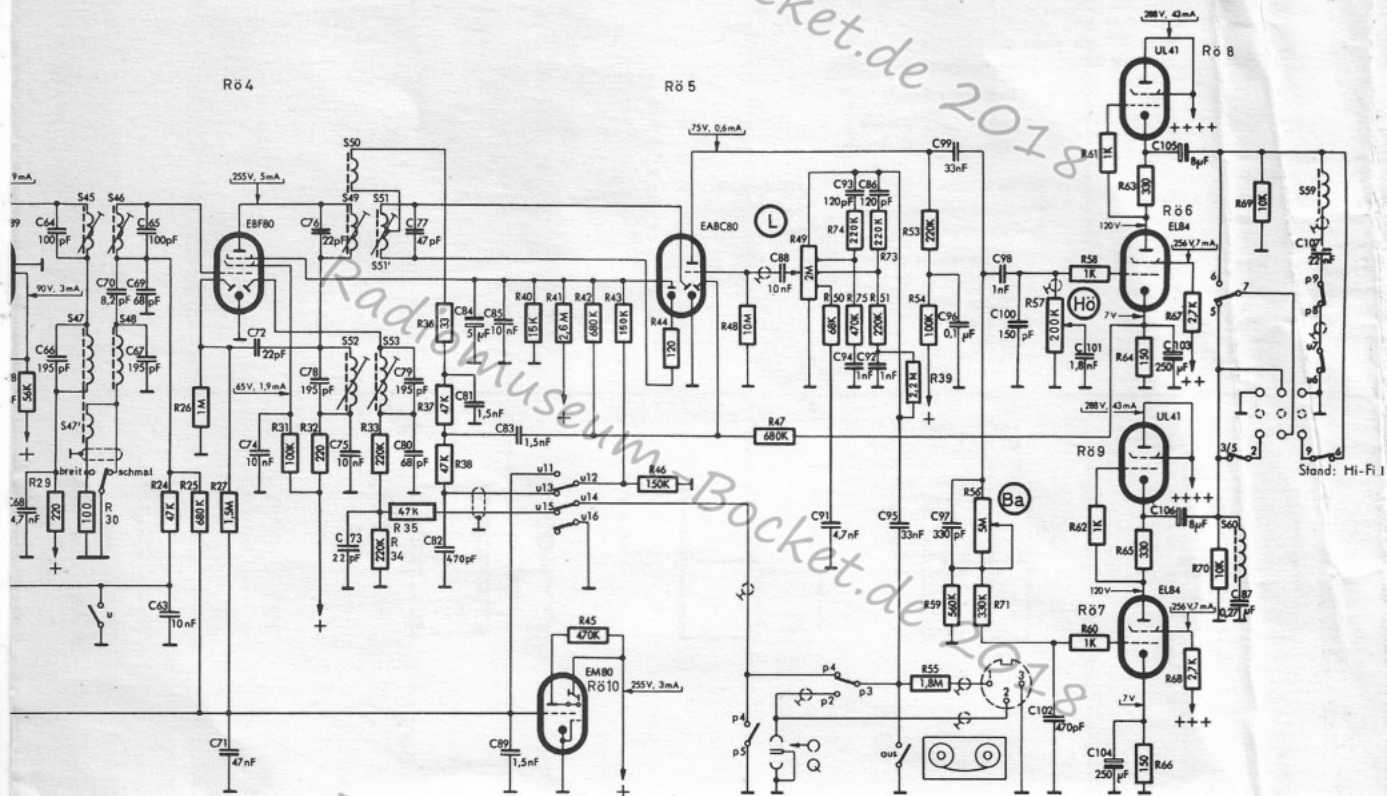

AUS	TA	LW	MW	KW	UKW
a	p	l	m	k	u
1x	1x	1a		1a	1a
2•	2a	2a	2a	2a	2a
3x	3a	3a	3a	3a	3a
4•	4a	4a	4a	4a	4a
5•	5a	5a	5a	5a	5a
6x	6a	6a	6a	6a	6a
7•	7a	7a	7a	7a	7a
8•	8a	8a	8a	8a	8a
9•	9a	9a	9a	9a	9a
10•	10x	10a	10a	10a	10a

Tastenschalter
auf Lötunkte gesehen.
Stand: MW/Taste gedrückt



Stand: Hi-Fi I
Stellungen:
Hi-Fi I
I + II
außen II

o = Schalterflur; x = Stützpunkt;
Hub = 1 Kontaktabstand

9, 8, 45, 47, 47', 46, 48,	50, 49, 52, 25, 51, 51', 53,	60,
28, 29, 30, 1, 24, 26, 25, 2, 3, 27,	31, 32, 33, 34, 35, 36, 37, 38,	40, 41, 42, 45, 43, 46, 44,
48, 49, 64, 66, 1, 70, 65, 69, 67, 63, 2, 71,	72, 74, 6, 75, 76, 78, 3, 4, 23, 24, 77, 79, 80, 82,	84, 81, 85, 83, 89,
C14,	C71,	C73,

Abgleich-Reihenfolge	Taste	Zeiger auf	Meßsender- frequenz	Ankopplung des Meßsenders über	Verstimmen	Abgleichen	Anzeige	Hinweis
ZF-Kreise	AM	MW	• 1550 kHz	460 kHz	32 nF an g1 EF 89	S52, S48	S53, S52, S47, S48	max. Output
ZF-Sperrkreis	AM	MW	• 550 kHz		32 nF an g1 ECH 81	S43	S42, S43	min. Output
Abstimmkreise	MW	MW	• 550 kHz • 1550 kHz	550 kHz 1550 kHz	künstliche Antenne an AM-Antennenbuchse und Ferroceptor auf Außenantenne		S36, S31' C51, C36	max. Output
Abstimmkreise	LW	LW	• 151 kHz • 340 kHz	151 kHz 340 kHz			S34, S32' C52, C37	max. Output
Abstimmkreise	KW	KW	• 5,85 MHz • 12,4 MHz	5,85 MHz 12,4 MHz			S38, S29 C48, C35	min. Output
Spiegelsperre	LW	LW	190 kHz	1110 kHz	Peilrahmen auf Ferroceptor		S33	max. RV max. Output
ZF-Kreise	FM	UKW	101 MHz	10,7 MHz FM ca. 15 kHz Hub	10nF an g1 EBF 80	S51	S49 S51	max. RV
ZF-Sperrkreise	FM	UKW			10nF an g1 EF 89	S46	S45, S46	max. RV
Abstimmkreise	FM	UKW			10nF an g1 ECH 81	S41	S40, S41	min. Output
					Metalldüse auf Glaskolben der FCC 85	S23	S22, S23	max. Output
					Symmetrie-Glied an Dipolbuchsen		S12, S13 C20, C17 S20, S17	min. Output max. Output

Für alle Abgleicharbeiten Lautstärkeregler, Baß- und Höhenregler auf Maximum und Bandbreite „schmal“. Outputmeter (800 Ohm) an Baßkanal. Die Zeiger sollen in den Anschlägen hinter den Marken am Skalende stehen. Beim Abgleichen der FM-ZF-Kreise ist, außer dem Outputmeter, über 100 kΩ ein Röhrenvoltmeter, z. B. PHILIPS GM 7635 oder GM 6004, parallel zu C 84 anzuschließen. Die Ausgangsspannung des Meßsenders ist so zu regeln, daß beim Abgleichen ca. -6V vom RV angezeigt werden. Der Masseanschluß des Signals ist an Punkt 10 der zugehörigen Röhre zu legen.



PHILIPS SERVICE

WA187LZ(-01)

Bassreflexbox

WA188LZ

Hochtonstrahler

WA193LZ

Hochtonstrahler

WE 670 15
WE 670 29

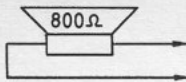

WE 670 19 WE 670 06
HA 372 00 HA 372 01

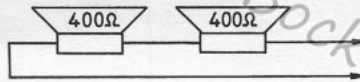

auf richtige Polung achten

WA 188LZ - Hochtonstrahler

Mechanische Ersatzteile

Pos.	Bezeichnung	Code-Nummer
1	Gehäuse, elfenbein	WE 728 20
2	Gehäuse, nußbaumfarbig	WE 728 19
3	Lautsprecher, rund	WE 670 19
4	Lautsprecher, oval	WE 670 06
5	PHILIPS Emblem	WE 357 36
6	Dreipoliger Stecker	WE 398 95
7	Anschlußkabel, meterweise	33 999 99

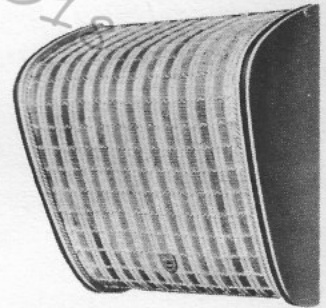

WA 193LZ - Hochtonstrahler

Mechanische Ersatzteile

Pos.	Bezeichnung	Code-Nummer
1	Gehäuse, kompl.	HA 002 00
2	Lautsprecher, rund	HA 372 00
3	Lautsprecher, oval	HA 372 01
4	Dreipoliger Stecker	WE 398 95
5	Anschlußkabel, meterweise	33 999 99
6	PHILIPS - Merkzeichen	WE 315 13

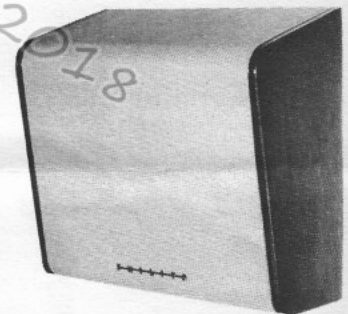

WA 187 LZ (-01) Baßreflexbox

Mechanische Ersatzteile

Pos.	Bezeichnung	Code-Nummer
1	Lautsprecher für WA 187LZ	WE 670 15
2	Lautsprecher für WA 187LZ-01	WE 670 29
3	Lautsprechertuch, meterweise	WE 723 31
4	PHILIPS - Merkzeichen	WE 315 13
5	Dreipoliger Stecker	WE 398 95
6	Anschlußkabel, meterweise	33 999 99

